

The logo consists of the letters 'ELBA' in a bold, white, sans-serif font, centered within a black, horizontally-oriented oval shape.

ELBA

Double oven

Instruction for the use - Installation advice

Dear Customer,

Thank you for having purchased and given your preference to our product.

The safety precautions and recommendations reported below are for your own safety and that of others. They will also provide a means by which to make full use of the features offered by your appliance.

Please preserve this booklet carefully. It may be useful in future, either to yourself or to others in the event that doubts should arise relating to its operation.

This appliance must be used only for the task it has explicitly been designed for, that is for cooking foodstuffs. Any other form of usage is to be considered as inappropriate and therefore dangerous.

The manufacturer declines all responsibility in the event of damage caused by improper, incorrect or illogical use of the appliance.

IMPORTANT INSTRUCTIONS AND ADVICE FOR THE USE OF ELECTRICAL APPLIANCES

The use of any electrical appliance requires the compliance with some basic rules, namely:

- do not touch the appliance with wet or damp hands (or feet)
- do not use the appliance bare feet
- do not allow the appliance to be operated by children or disabled without overseeing.

The manufacturer cannot be deemed responsible for damages caused by wrong or incorrect use.

Read the instructions carefully before installing and using the appliance.

IMPORTANT PRECAUTIONS AND RECOMMENDATIONS

After having unpacked the appliance, check to ensure that it is not damaged and that the oven door closes correctly. In case of doubt, do not use it and consult your supplier or a professionally qualified technician.

Packing elements (i.e. plastic bags, polystyrene foam, nails, packing straps, etc.) should not be left around within easy reach of children, as these may cause serious injuries.

- Do not attempt to modify the technical characteristics of the appliance as this may cause danger to users.
- Do not carry out cleaning or maintenance operations on the appliance without having previously disconnected it from the electric power supply.
- If you should decide not to use this appliance any longer (or decide to substitute an older model), before disposing of it, it is recommended that it be made inoperative in an appropriate manner in accordance to health and environmental protection regulations, ensuring in particular that all potentially hazardous parts be made harmless, especially in relation to children who could play with unused appliances.
- After use, ensure that the knobs are in off position.
- Do not allow children or other unqualified people to use the appliance without your supervision.
- Keep children away from the oven when it is in use.
- Some appliances are supplied with a protective film on steel and aluminium parts. This film must be removed before using the appliance.
- **Fire risk!** Do not store flammable material in the oven.
- Do not line the oven walls with aluminium foil. Do not place baking trays or the drip tray on the base of the oven chamber.
- The manufacturer declines all liability for injury to persons or damage to property caused by incorrect or improper use of the appliance.
- The various components of the appliance are recyclable. Dispose of them in accordance with the regulations in force in your country. If the appliance is to be scrapped, cut off the power cord.

USING THE OVEN FOR THE FIRST TIME

It is advised to follow these instructions:

- Furnish the interior of the oven by placing the wire racks as described at chapter “Cleaning and maintenance”.
- Insert shelves and tray.
- Turn on the oven, and operate at the maximum temperature in order to eliminate any traces of grease on the heating elements (see oven operating instructions).
- Let the oven cool down and then clean the interior of the oven with cloth soaked in water and detergent (neutral) then dry carefully.

1 CONTROL PANEL

Fig. 1.1

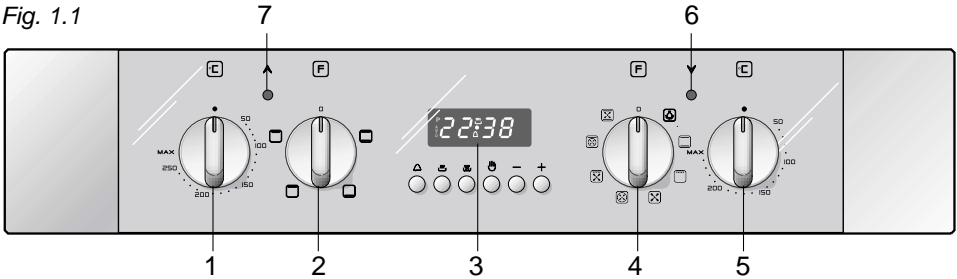

CONTROL PANEL

1. Oven temperature knob (Top oven)
2. Function selector knob (Top oven)
3. Digital electronic programmer (Main oven only)
4. Function selector knob (Main oven)
5. Oven temperature knob (Main oven)
6. Main oven temperature indicator light
7. Top oven temperature indicator light

NB: Your appliance has been fitted with a cooling fan to achieve optimum efficiency of the controls and to ensure lower surface temperatures are maintained.

2 HOW TO USE THE CONVENTIONAL OVEN (top oven)

GENERAL FEATURES



The convection oven is equipped with 3 electrical heating elements:

- 2 elements (upper and lower) for normal oven cooking
- 1 grill element, on the top of the oven, for grilling which must be done with the oven door closed.

The input of the elements is:

- Upper element, 700 W
- Lower element, 1000 W
- Grill element, 2000 W

NOTE:

Upon first use, it is advisable to operate the oven at the maximum temperature (thermostat knob on position MAX) for 60 minutes in the position  and for another 15 minutes in the  mode in order to eliminate any traces of grease from the electrical resistances.

WARNING:

The door is hot, use the handle.

OPERATING PRINCIPLES

Heating and cooking in the CONVENTIONAL oven are obtained in the following ways:

a. by normal convection

The heat is produced by the upper and lower heating elements.

b. by radiation

The heat is radiated by the infra red grill element (use with the oven door closed).

Attention: the oven door becomes very hot during operation. Keep children away.

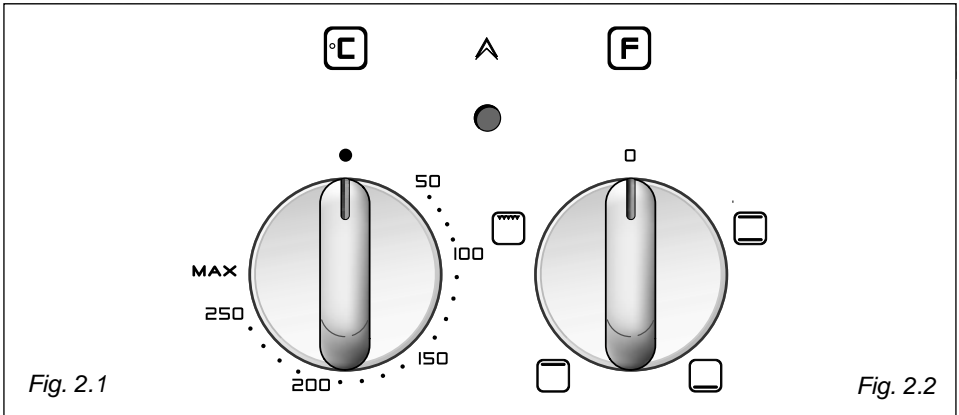

TEMPERATURE KNOB (fig. 2.1)

To turn on the heating elements of the oven, set the function selector knob to the required position and the temperature knob to the desired temperature.

To set the temperature, turn the control knob to line the indicator mark with the required temperature.

The elements will turn on or off automatically to maintain the correct temperature.

FUNCTION SELECTOR KNOB (fig. 2.2)

Rotate the knob clockwise to set the oven for one of the following functions.

OVEN LIGHT

The oven is equipped with a light that illuminates the oven to enable visually controlling the food that is cooking.

This light is controlled by the selector knob (fig. 2.2); it remains on in all the cooking modes.



TRADITIONAL CONVECTION COOKING

The upper and lower heating elements are switched on. The heat is diffused by natural convection and the temperature must be regulated between 50°C and 250°C with the thermostat knob.

It is necessary to preheat the oven before introducing the foods to be cooked.

Recommended for:

For foods which require the same cooking temperature both internally and externally, i. e. roasts, spare ribs, meringue, etc.



LOWER HEATING ELEMENT

In this position only the lower element is switched on. Heat is distributed by natural convection. The thermostat can be set between 50°C and 250°C; higher temperatures are not available.

Recommended for:

This mode is particularly suitable to complete cooking of dishes that require higher temperature at the bottom.



UPPER HEATING ELEMENT

In this position only the upper element is switched on. Heat is distributed by natural convection. The thermostat can be set between 50°C and 250°C; higher temperatures are not available.

Recommended for:

This mode is particularly suitable to complete cooking of dishes that require higher temperature at the top.



GRILLING

The infra-red heating element is switched on. The heat is diffused by radiation. Use with the oven door **closed** and the temperature knob set between 50°C and 200°C. For correct use see chapter "USE OF THE GRILL".

Recommended for:

Intense grilling action for cooking with the broiler; browning, crisping, "au gratin", toasting, etc.

Always grill with the oven door closed

USE OF THE GRILL

Leave to warm up for approximately 5 minutes with the door **closed**.

Place the food inside positioning the rack as near as possible to the grill.

Insert the drip pan under the rack to collect the cooking juices.

Always grill with the oven door closed.

Grill with the oven door closed and for no longer than 30 minutes at any one time.

Attention: the oven door becomes very hot during operation.

Keep children away.

OVEN COOKING

Before introducing the food, preheat the oven to the desired temperature.

For a correct preheating operation, it is advisable to remove the tray from the oven and introduce it together with the food, when the oven has reached the desired temperature.

Check the cooking time and turn off the oven 5 minutes before the theoretical time to recuperate the stored heat.

3 HOW TO USE THE MULTIFUNCTION OVEN (bottom main oven)



GENERAL FEATURES

The multi-function oven can be programmed for 7 different functions to satisfy every cooking need.

The 7 positions are thermostatically controlled and are obtained by a combination of 4 heating elements which are:

- Lower element 1300 W
- Upper element 1000 W
- Grill element 2000 W
- Circular element 2200 W

NOTE:

Before using for the first time, it is advisable to operate the oven at the maximum temperature (temperature knob on position 250°C) for 60 minutes in the position  and  to eliminate possible traces of grease on the heating elements.

Repeat the operation for another 15 minutes with the grill element on as explained in the GRILLING AND AU GRATIN and USE OF THE GRILL section.

WARNING:

The door is hot, use the handle.

OPERATING PRINCIPLES

Heating and cooking in the MULTIFUNCTION oven are obtained in the following ways:

a. by normal convection

The heat is produced by the upper and lower heating elements.

b. by forced convection

The circular heating element and fan constantly circulate heated air over the food in the oven for a more rapid and even cooking process.

It is possible to cook several dishes simultaneously.

c. by semi-forced convection

The heat produced by the upper and lower heating elements is distributed throughout the oven by the fan.

d. by radiation

The heat is produced by the infra red grill element.

e. by radiation and ventilation

The heat from the infra red grill element is distributed throughout the oven by the fan.

f. by ventilation

The food is defrosted by using the fan only function without heat.

Attention: the oven door becomes very hot during operation. Keep children away.

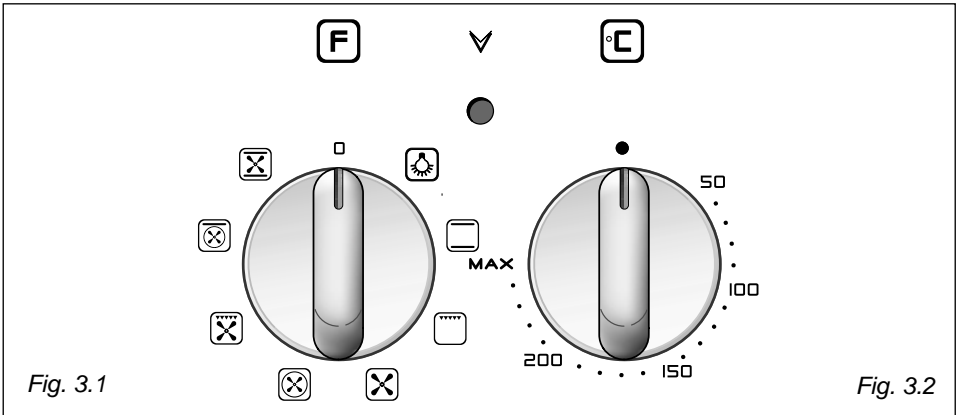

TEMPERATURE KNOB (fig. 3.2)

To turn on the heating elements of the oven, set the function selector knob to the required position and the temperature knob to the desired temperature.

To set the temperature, turn the control knob to line the indicator mark with the required temperature.

The elements will turn on or off automatically to maintain the correct temperature.

FUNCTION SELECTOR KNOB (fig. 3.1)

Rotate the knob clockwise to set the oven to one of the following functions:



OVEN LIGHT AND COOLING FAN

By turning the knob onto this setting (see picture aside) we light the oven cavity (15 W). The oven remains alight while any of the functions is on.

Please note: on all cooking positions with heat (bottom oven only) you may notice the cooling fan come on after you have been cooking for a short period of time, this is normal and it will stay on for a short time after you have finished cooking.



TRADITIONAL CONVECTION COOKING

The upper and lower heating elements are switched on.

The heat is diffused by natural convection and the temperature must be set between 50°C and MAX position.

It is necessary to preheat the oven before introducing the foods to be cooked.

Recommended for:

For foods which require the same cooking temperature both internally and externally, i. e. roasts, spare ribs, meringue, etc.



GRILLING

The infra-red heating element is switched on. The heat is diffused by radiation. Use with the oven door **closed** and the temperature knob set between 50°C and 225°C. For correct use see chapter “USE OF THE GRILL”.

Recommended for:

Intense grilling action for cooking with the broiler; browning, crisping, “au gratin”, toasting, etc.

It is recommended that you do not grill for longer than 30 minutes at any one time.

Attention: the oven door becomes very hot during operation.

Keep children away.



DEFROSTING FROZEN FOODS

Only the oven fan is on. To be used with the temperature knob in the off “●” position because the other positions have no effect.

The defrosting is done by simple ventilation without heat.

Recommended for:

To rapidly defrost frozen foods; 1 kilogram requires about one hour.

The defrosting times vary according to the quantity and type of foods to be defrosted.



HOT AIR COOKING

The circular element and the fan are on.

The heat is diffused by forced convection and the temperature must be regulated between 50°C and MAX position with the temperature knob.

It is not necessary to preheat the oven.

Recommended for:

For foods that must be well done on the outside and tender or rare on the inside, i. e. lasagna, lamb, roast beef, whole fish, etc.



VENTILATED GRILL COOKING

The infra-red grill and the fan are on. The heat is mainly diffused by radiation and the fan then distributes it throughout the oven.

The temperature must be regulated between **50°C and 200°C** with the temperature knob.

It is necessary to preheat the oven for about 5 minutes.

For correct use see chapter "GRILLING AND AU GRATIN".

Grilling with the oven door closed.

It is recommended that you do not grill for longer than 30 minutes at any one time.

Attention: the oven door becomes very hot during operation.

Keep children away.

Recommended for:

For grill cooking when a fast outside browning is necessary to keep the juices in, i. e. veal steak, steak, hamburger, etc.



MAINTAINING TEMPERATURE AFTER COOKING OR SLOW COOKING

The upper element and the circular element connected in series, are switched on; also the fan is on. The heat is diffused by forced convection with most of the heat being produced by the upper element.

The temperature must be set between 50° and 140 °C with the temperature knob.

Recommended for:

To keep foods hot after cooking. To slowly heat already cooked foods.



CONVECTION COOKING WITH VENTILATION

The upper and lower heating elements and the fan turn on.

The heat coming from the top and bottom is diffused by forced convection.

The temperature must be set between 50°C and MAX position with the temperature knob.

Recommended for:

For foods of large volume and quantity which require the same internal and external degree of cooking; for ex: rolled roasts, turkey, legs, cakes, etc.

BOTTOM OVEN COOKING ADVICE

STERILIZATION

Sterilization of foods to be conserved, in full and hermetically sealed jars, is done in the following way:

- Set the switch to position .
- Set the thermostat knob to position 185 °C and preheat the oven.
- Fill the dripping pan with hot water.
- Set the jars onto the dripping pan making sure they do not touch each other and the door and set the thermostat knob to position 135 °C.

When sterilization has begun, that is, when the contents of the jars start to bubble, turn off the oven and let cool.

REGENERATION

Set the switch to position  and the thermostat knob to position 150° C.

Bread becomes fragrant again if wet with a few drops of water and put into the oven for about 10 minutes at the highest temperature.

ROASTING

To obtain classical roasting, it is necessary to remember:

- that it is advisable to maintain a temperature between 180 and 200 °C.
- that the cooking time depends on the quantity and the type of foods.

GRILLING AND “AU GRATIN”

Grilling may be done using the grill+fan setting , in this setting the hot air completely surrounds the food that is to be cooked, to give a more even and rapid cooking process.

Set the temperature knob **between 50°C and 200°C**, preheat the oven, then simply place the food on the grid.

Close the door until grilling is complete. Adding a few dabs of butter before the end of the cooking time gives the golden “au gratin” effect.

Grilling with the oven door closed.

It is recommended that you do not grill for longer than 30 minutes at any one time.

Attention: the oven door becomes very hot during operation.

Keep children away.

**The external parts of the oven become hot during operation.
Keep children well out of reach.**

COOKING DIFFERENT DISHES AT THE SAME TIME

With the function selector in position  the ventilated oven allows you to cook different types of food at the same time. Fish, cakes and meat can be cooked together without the smells and flavours mixing.

The only precautions required are the following:

- The cooking temperatures must be as close as possible with a maximum difference of 20° - 25°C between the different foods.
- Different dishes must be placed in the oven at different times according to the cooking time required for each one. This type of cooking obviously provides a considerable saving on time and energy.

USE OF THE GRILL

Set the function selector knob to position  and the temperature knob **between 50°C and 225°C**.

Leave to heat up for approximately 5 minutes with the door **closed**.

Introduce the food to be cooked, positioning the grill pan as close to the grill as possible.

Always grill with the oven door closed.

Grill with the oven door closed and for no longer than 30 minutes at any one time.

Attention: the oven door becomes very hot during operation. Keep children away.

COOKING EXAMPLES

Preheat the oven to the required temperature (the temperature light on the control panel will go out) and place the food inside.

Remember to use ovenproof dishes and to alter the oven temperature during cooking if necessary.

For the consumer's information, the following table gives some dishes with their relative cooking temperatures in °C.

The cooking time varies with the quantity.







Cakes	180°
Doughnuts	180°
Cheese soufflé	200°
Potatoes soufflé	200°
Roast veal	200°
Spinach crepes	200°
Potatoes in milk	200°
Chicken breasts in tomato	200°
Sole fish filet	200°
Whiting	200°
Cream puffs	200°
Plum pie	200°
Meat balls	200°
Veal meatloaf	200°
Grilled chicken - roast chicken	220°
Baked lasagna	220°
Roast beef	220°
Oven cooked pasta	220°
Lemon cake	220°
Pizza with anchovies	225°
Rice creol	225°
Baked onions	225°
Stuffed potatoes	225°
Grilled veal joint	225°
Turkish shishkebab	225°
Marmalade pie	225°
Pound cake	225°

4 ELECTRONIC PROGRAMMER (Bottom main oven only)

The electronic programmer performs the following functions:

- 24 hours clock with illuminated display
- Timer (up to 23 hours and 59 minutes)
- Program for automatic oven cooking
- Program for semi-automatic oven cooking.

Description of the buttons:

-  Timer
-  Cooking period
-  End of cooking time
-  Manual position and cancellation of the inserted cooking program
-  To increase the numbers on the digital display.
-  To decrease the numbers on the digital display.

Description of the illuminated symbols:

AUTO - *flashing* - Programmer in automatic position but not programmed

AUTO - *illuminated* - Programmer in automatic position with program set.

 Automatic cooking taking place

 Timer in operation

 and **AUTO** - *flashing* - Program error.
(The time of day lies between the calculated cooking start and end time).

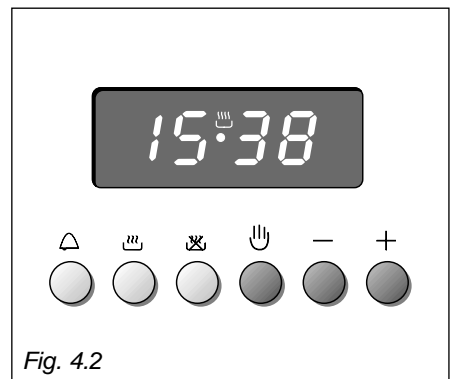
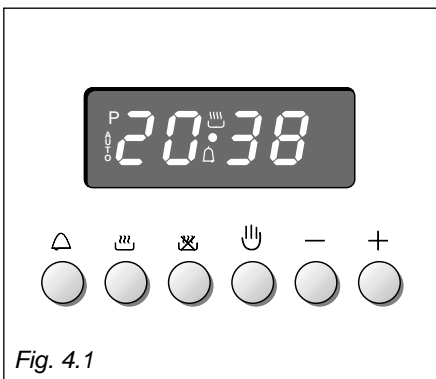

NOTE: Select a function by the respective button and, in 5 seconds, set the required time with the **+** / **-** buttons. After a power cut the display resets to zero and cancels the set programs.



ELECTRONIC CLOCK (fig. 4.2)



The programmer is equipped with an electronic clock with an illuminated display which indicates hours and minutes. Upon immediate connection of the oven or after a power cut, three zeros will flash on the programmer display.

To set the correct time of day it is necessary to push the  button and then the $+$ or $-$ button until you have set the correct time (fig. 4.2).

Or push the two buttons   simultaneously and at the same time push the $+$ or $-$ button.

Note: If the clock is reset it deletes any previously set programs

NORMAL COOKING WITHOUT THE USE OF THE PROGRAMMER

To manually use the oven, without the aid of the programmer, it is necessary to cancel the flashing **AUTO** by pushing the button  (**AUTO** will be switched off and the symbol  will illuminate - Fig. 4.3).

Attention: If the **AUTO** is lit (which means a cooking program has already been set), push the button  to cancel the program and return to manual operation.

If the oven is switched on, you must switch off manually.

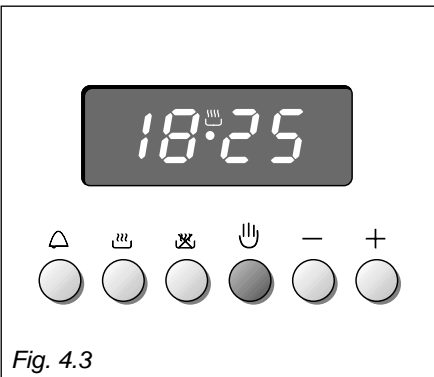



ELECTRONIC TIMER

The timer consists only of a buzzer which may be set for a maximum period of 23 hours and 59 minutes.

If the **AUTO** symbol is flashing push the  button.

To set the time, push the  button and the $+$ or $-$ until you obtain the desired time in the display panel (fig. 4.4).

Once set, the time will appear on the panel and the  symbol will be lit.

The countdown will start immediately and may be seen at any time on the panel by simply pressing the button .

At the end of the time, the  symbol will disappear and the buzzer will sound continuously for approximately 7 minutes or until a button is pressed (not the $+$ / $-$ buttons). After a short time the display will revert back to the time of day.

SETTING THE FREQUENCY OF THE AUDIBLE SIGNAL

The buzzer has 3 different tones and can be changed by pressing the $-$ button, but only when the time of day is displayed.

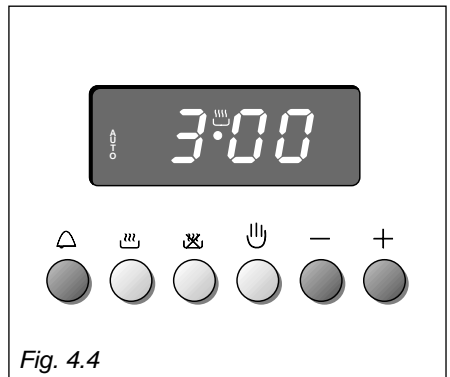









AUTOMATIC OVEN COOKING

To cook food automatically in the oven, it is necessary to:

1. Set the length of the cooking time
2. Set the end of the cooking time
3. Set the temperature and the oven cooking program.

These operations are done in the following way:

1. Set the length of the cooking time by pushing the  button and the  button to increase, or  to decrease if you have passed the desired time (fig. 4.5). The **AUTO** and the  symbol will light up.
2. Set the end of the cooking time by pressing the  button (the cooking time already added to the clock time will appear), and the  button (fig. 4.6); if you pass the desired time you can go back by pushing the  button.

After this setting, the  symbol will disappear. If after this setting, the **AUTO** flashes on the display and a buzzer sounds, it means there was an error in the programming, that is that the cooking cycle has been superimposed on the clock. In this case, change the end of cooking time or the cooking period itself by following the instructions above.



3. Set the temperature and the cooking program by using the function selector switch and temperature knobs of the oven (see specific chapters).

Once the oven is programmed it will switch on automatically at the right time to stop the cooking at the desired end time.

During cooking, the  symbol remains lit.

By pushing the  button you can see the time that remains until the end of cooking.

The cooking program may be cancelled at any time by pushing .

At the end of the cooking time the oven will turn off automatically and, the  symbol will switch off. **AUTO** will flash and a buzzer will sound, which can be turned off by pushing any of the buttons except the  /  buttons .

Turn the function selector and temperature knobs to zero and put the programmer onto “manual” by pressing the  button.

Attention: After a power cut the clock will reset to zero and cancel the programs set.

After a power cut, three zeros will flash on the display.

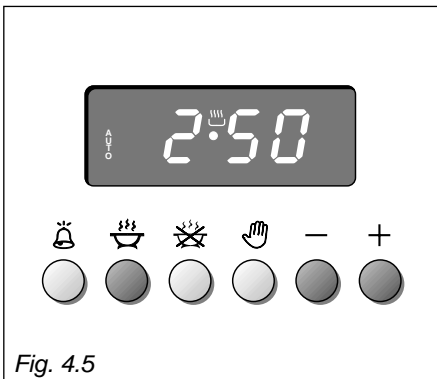

Fig. 4.5

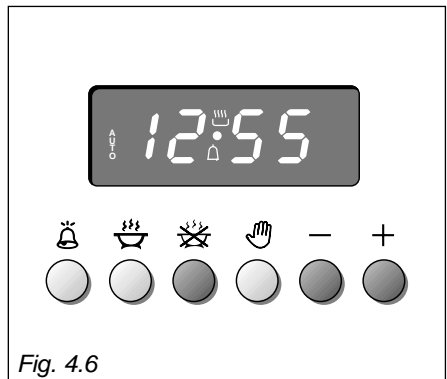



Fig. 4.6



SEMI - AUTOMATIC COOKING

This is used to automatically switch off the oven after the desired cooking period has elapsed.

Set the length of the cooking period by pushing the  button and the $+$ button to increase, or $-$ to decrease if you have passed the desired time (Fig. 4.7).

AUTO and the  symbol will be lit. Then set the temperature and the cooking program using the function selector switch and temperature knobs (see relevant chapters).

The oven switches on and switches off automatically at the end of the desired cooking time.

During cooking, the  symbol remains lit and by pressing the button  you can see the remaining cooking time.

The cooking program can be cancelled at any time by pushing the  button.

At the end of the cooking period, the  symbol will disappear, **AUTO** will flash and a buzzer will sound and can be stopped by pushing any of the buttons except the $+$ / $-$ buttons.

Turn the function selector and temperature knobs to zero and put the programmer onto "manual" by pressing the  button.

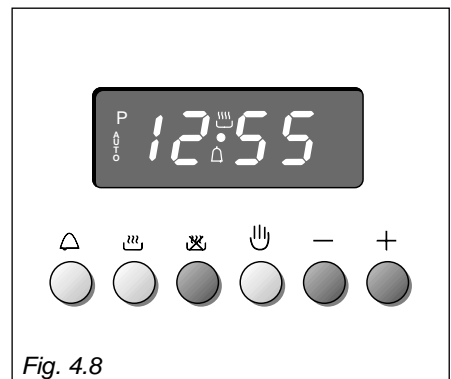
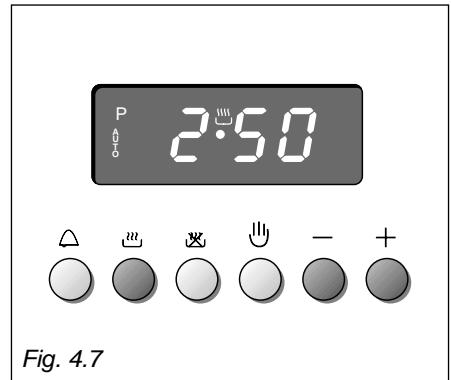

GENERAL ADVICE

Important:

Before cleaning or carrying out any maintenance disconnect the appliance from the electrical supply.

It is advisable to clean when the appliance is cold especially when cleaning the enamelled parts.

Avoid leaving acidic substances (lemon juice, vinegar, etc.) on the surfaces.

Avoid using cleaning products with a chlorine or acidic base.

The oven must always be cleaned after every use, using suitable products.

STAINLESS STEEL SURFACES WITH ANTI-FINGERPRINT TREATMENT

CAUTION:

The stainless steel front surfaces used in this oven are protected with a Special Lacquer to reduce finger-print marks.

To avoid damaging this lacquer, do not clean the stainless steel with abrasive cleaners or abrasive cloths or scouring pads.

ONLY SOAPY/WARM WATER MUST BE USED TO CLEAN THE STAINLESS STEEL SURFACES.

STAINLESS STEEL AND ALUMINIUM PARTS AND SILK-SCREEN PRINTED SURFACES

Clean using an appropriate product. Always dry thoroughly.

IMPORTANT: these parts must be cleaned very carefully to avoid scratching and abrasion. You are advised to use a soft cloth and neutral soap.

ENAMELLED PARTS

All the enamelled parts must be cleaned with a sponge and soapy water only or other non-abrasive products.

Dry preferably with a chamois leather.

INSIDE OF OVEN

The oven must be always cleaned after every use, using suitable products and keeping in mind that its operation for 30 minutes on the highest temperature eliminates most grime reducing it to ashes.

Do not use a steam cleaner because the moisture can get into the appliance thus make it unsafe.

Do not store flammable material in the ovens.

REPLACING THE OVEN LIGHT

Before any maintenance is started involving electrical parts of the appliance, it must be disconnected from the power supply.

- Let the oven cavity and the heating elements cool down;
- Switch off the electrical supply;
- Unscrew the protective cover (fig. 5.1);
- Unscrew and replace the bulb with a new one suitable for high temperatures (300°C) having the following specifications: 220/230V 50/60 Hz, 15W, E14.
- Refit the protective cover

NOTE: Oven bulb replacement is not covered by your guarantee

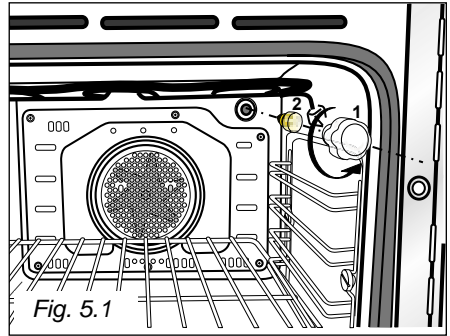

GREASE FILTER (BOTTOM MAIN OVEN ONLY)

- A special screen is provided at the back of the oven to catch grease particles, mainly when meat is being roasted (fig. 5.2).
- When baking pastry etc. this filter should be removed.
- Always clean the filter after cooking as any solid residues on it might adversely affect the oven performance.

Fig. 5.2

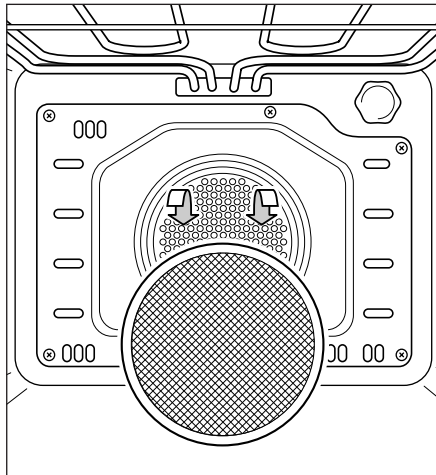

USING THE BOTTOM MAIN OVEN FOR THE FIRST TIME

- Slide off the sliding shelves to the oven wall by unscrewing the 2 screws as in Fig. 5.4. The grill is secured to the rear wall of the oven on a hinge system that allows it to be lowered to allow proper access when cleaning the oven ceiling (fig. 5.3).
- Clean the inside of the oven with a cloth soaked in water and neutral detergent and dry thoroughly.
- Assemble the sliding shelves on the oven wall as in Fig. 5.4. The sliding shelves facilitate the insertion and removal of shelves during cooking; they stop when pulled out to the maximum position. These shelves support all accessory trays and are dishwasher safe.
- Slide in the grease filter on the back of the oven as in Fig. 5.2.
- Position the shelf and tray as per Fig. 5.5.
- Switch on the bottom oven as described at page 8.

Fig. 5.3

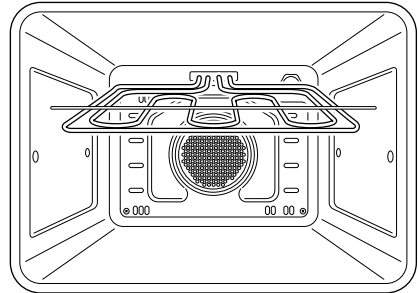

Fig. 5.4

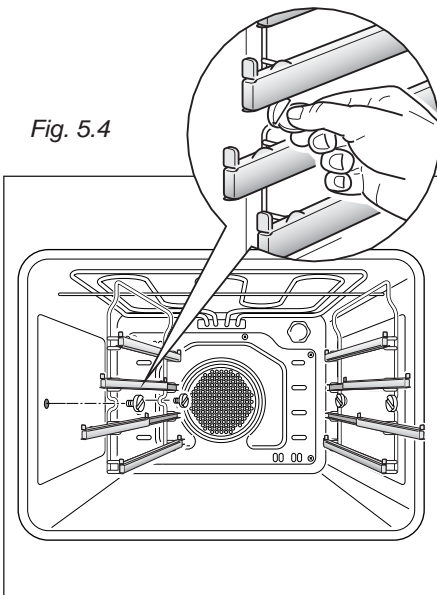
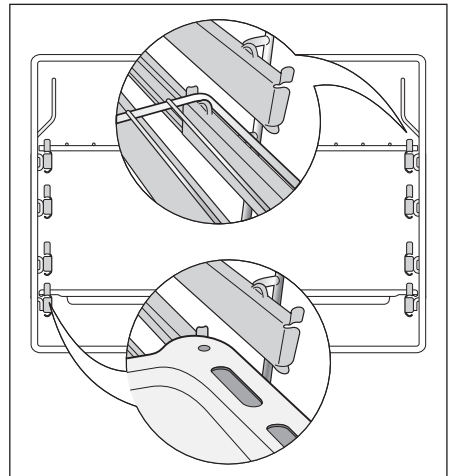

Fig. 5.5



USING THE TOP OVEN FOR THE FIRST TIME

- Clean the inside of the oven with a cloth soaked in water and neutral detergent and dry thoroughly.
- Assemble the sliding shelves on the oven wall as in Fig. 5.6. The sliding shelves facilitate the insertion and removal of shelves during cooking; they stop when pulled out to the maximum position. These shelves support all accessory trays and are dishwasher safe.
- Position the shelf and tray as per Fig. 5.7.
- Switch on the oven as described at page 5.

Fig. 5.6

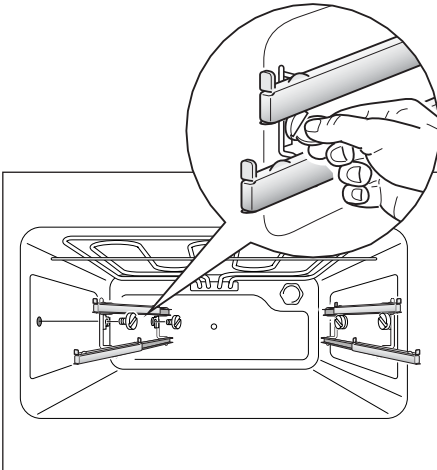
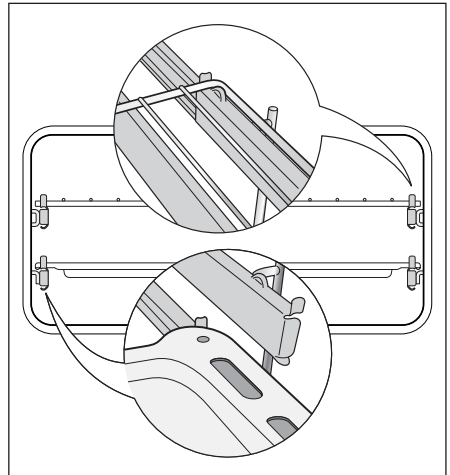

Fig. 5.7



TILTING GRILL OF THE TOP OVEN

- The grill is secured to the rear wall of the oven on a hinge system that allows it to be lowered to allow proper access when cleaning the oven ceiling (fig. 5.10).
- In the front the grill is secured to the ceiling by a hook A.

Unlocking the tilting grill (fig. 5.8)

1. Open the hook A.
2. Gently pull down the grill as shown in the figure 5.10.

Locking the tilting grill (fig. 5.9)

1. Gently lift up the grill.
2. Close the hook A on the grill bar.

Fig. 5.8

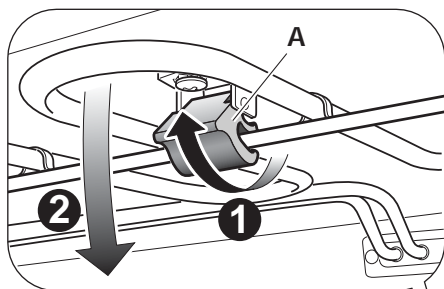

Fig. 5.9

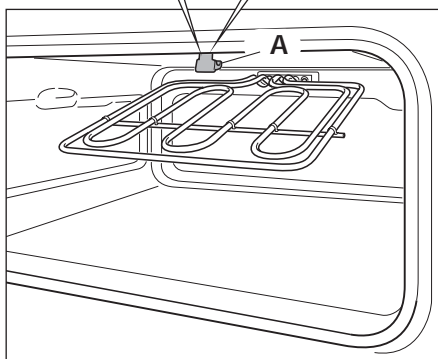
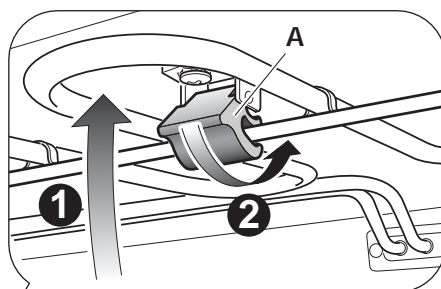
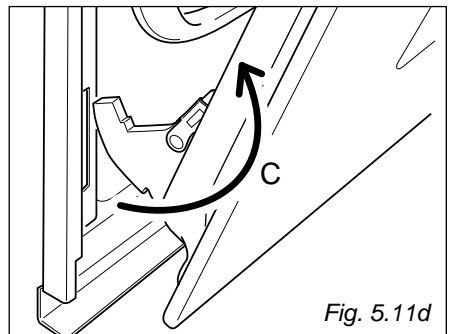
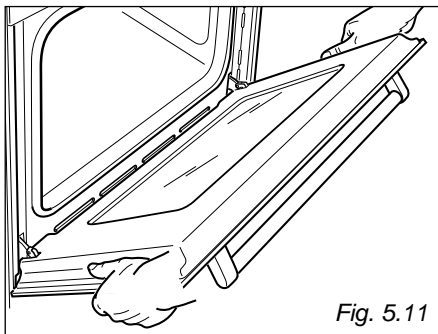
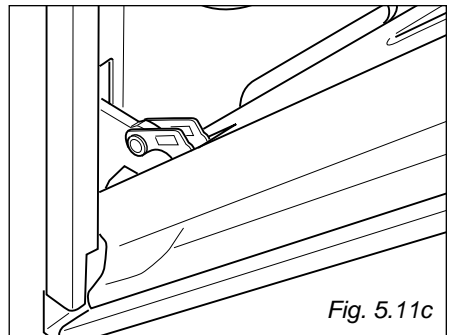
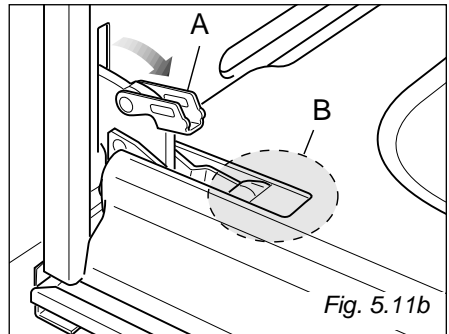
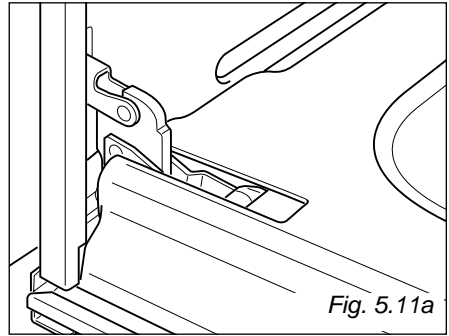

Fig. 5.10

REMOVING THE OVEN DOOR

The oven door can easily be removed as follows:

- Open the door to the full extent (fig. 5.11a).
- Open the lever “A” completely on the left and right hinges (fig. 5.11b).
- Hold the door as shown in fig. 5.11.
- Gently close the door (fig. 5.11) until left and right hinge levers “A” are hooked to part “B” of the door (fig. 5.11b).
- Withdraw the hinge hooks from their location following arrow “C” (fig. 5.11d).
- Rest the door on a soft surface.
- To replace the door, repeat the above steps in reverse order.



Advice for the installer

IMPORTANT

- ✓ Appliance installation and maintenance must only be carried out by QUALIFIED TECHNICIANS **and in compliance with the local safety standards.**
Failure to observe this rule will invalidate the warranty.
- ✓ Always unplug the appliance before carrying out any maintenance operations or repairs.

- ✓ *The walls surrounding the oven must be made of heat-resistant material.*
- ✓ *Take care NOT to lift the oven by the door handle.*

CE Declaration of conformity

- This double oven has been designed to be used only for cooking. Any other use (such as heating a room) is improper and dangerous.
- This double oven has been designed, constructed, and marketed in compliance with:
 - safety requirements of EEC Directive “Low voltage” 73/23;
 - safety requirements of EEC Directive “EMC” 89/336;
 - requirements of EEC Directive 93/68.

IMPORTANT

- The appliance should be installed by a **QUALIFIED INSTALLATION TECHNICIAN**.
The appliance must be installed in compliance with regulations in force.

You need the following housing area to fit your oven correctly.

The double oven is designed to fit into a cabinet of 600 mm width.

The double oven can be built in the kitchen units, but you must ensure that it is properly ventilated.

In the diagram the appliance is ventilated by means of the space in the top of the kitchen cabinet.

Lift the appliance into position onto the shelf, taking care **NOT** to lift it by the door handles.

If you open the oven doors, you will see some screw holes.

The oven should then be secured to the housing by fitting screws into these holes.

Remember the housing should not be free standing but be secured to the wall and/or adjacent fittings.

Dimensions (mm)	Oven	Housing
Height	888	877
Width	594	560
Depth	560	555 min.

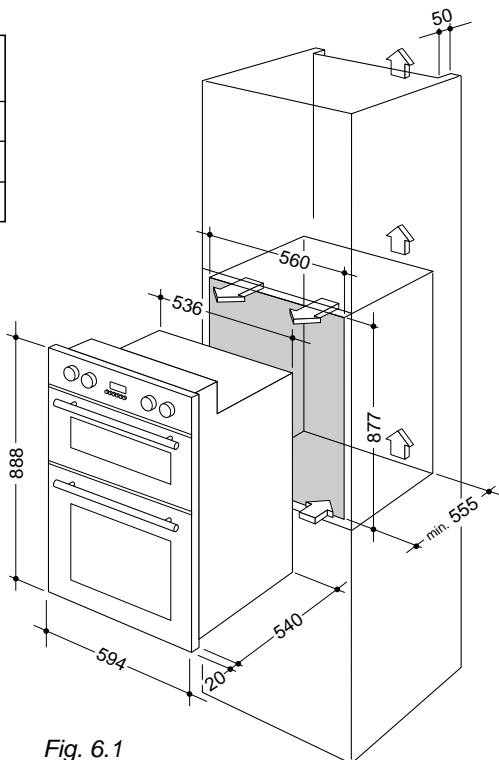

- The appliance must be housed in heat resistant units.
- **The walls of the units must be capable of resisting temperatures of 75 °C above room temperature.**

Fig. 6.1

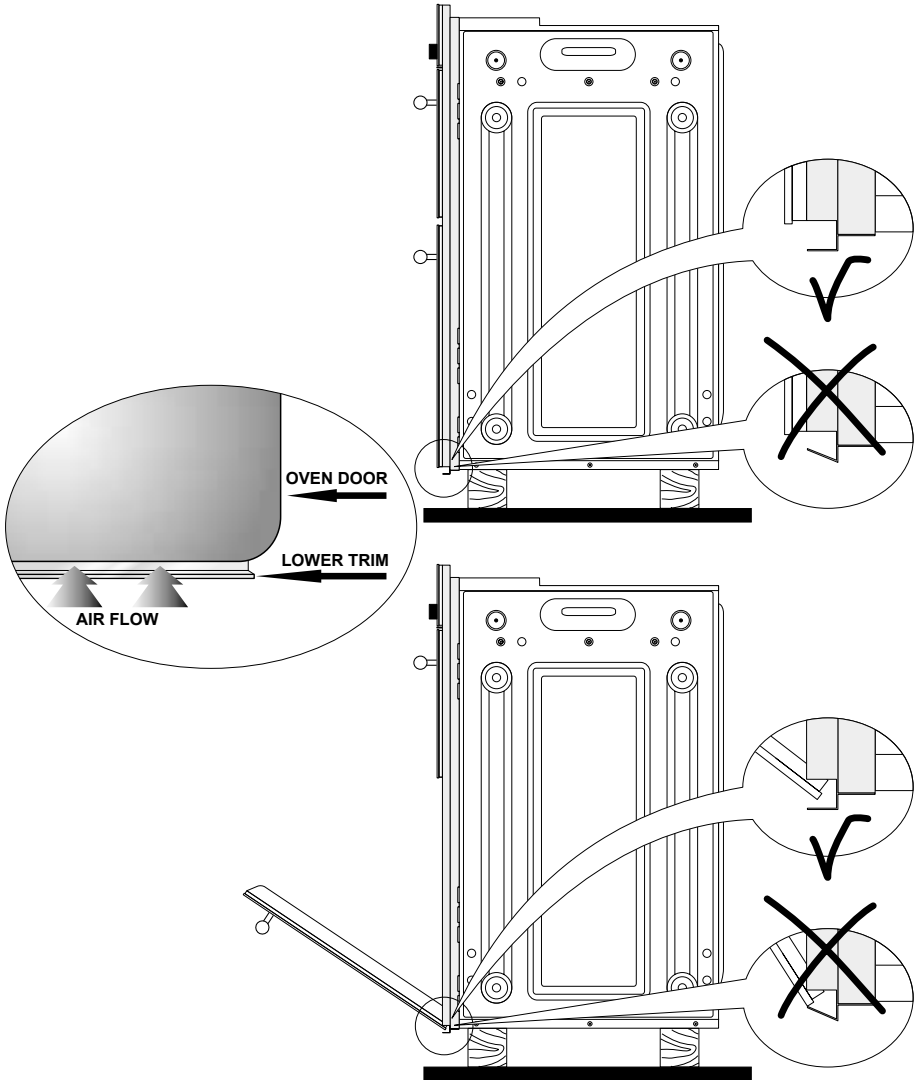

Fig. 6.2

IMPORTANT:

To avoid damage to the lower trim please note the following instructions.

The lower trim is designed to allow for good air circulation and the correct opening of the oven door.

To ensure the trim is not damaged due to the appliance being placed on the floor, the appliance should be suitably supported as in above illustrations.

After installation the appliance door should be slowly opened to ensure no damage has occurred.

No responsibility for lower trim damage will be accepted if these instructions have not been followed.

Before effecting any intervention on the electrical parts the appliance must be disconnected from the network.

GENERAL

- The connection to the electrical network must be carried out by qualified personnel and must be according to existing norms.
- The appliance must be connected to the electrical network verifying above all that the voltage corresponds to the value indicated on the specifications plate and that the cables section of the electrical plant can bear the load which is also indicated on the plate.
- The appliance can be connected directly to the mains placing an omnipolar switch with minimum opening between the contacts of 3 mm between the appliance and the mains.
- The power supply cable must not touch the hot parts and must be positioned so that it does not exceed 75°C at any point.
- Once the appliance has been installed, the switch must always be accessible.

FEEDER CABLE SECTION Type HO5RR-F or HO5VV-F

220/230 V ~ 3 x 2,5 mm² (**)

(**) – Connection to wall-mounting distribution panel.

IMPORTANT: this double oven must be connected to a suitable double pole control unit adjacent to the oven.

NO DIVERSITY CAN BE APPLIED TO THIS CONTROL UNIT.

The connection of the appliance to the grounding unit is mandatory. The manufacturer declines every responsibility for any inconvenience resulting from the inobservance of this condition.

CONNECTING THE DOUBLE OVEN MAINS CABLE

- Unscrew the screw A securing the cover plate B behind the oven (fig. 7.1).
- Remove the cover plate B.
- Remove the screws C from the cable clamp (fig. 7.2).
- Insert the mains cable (type H05RR-F or H05VV-F - 3x2,5 mm² section) into the cable protector P.
- Connect the phase and earth cables to the mains terminal connection block D.

 EARTH
N NEUTRAL
L LIVE

- Refit the cable clamp so that it clamps the outer sleeving of the cable, and screw the screws C.
- Refit the cover plate B and fix it with the screw A.

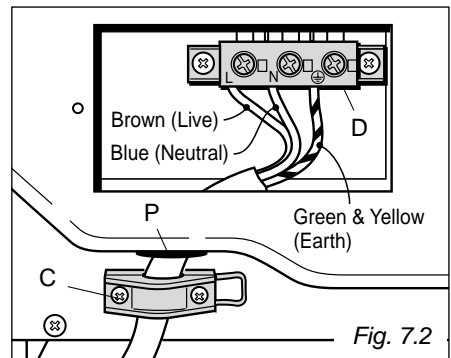
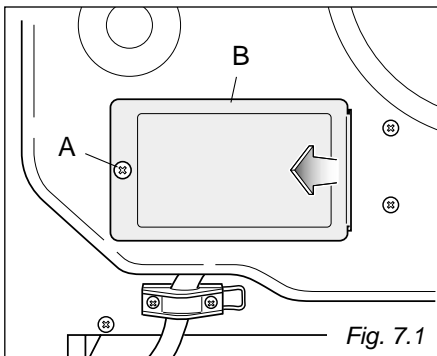

WARNING: This appliance must be earthed

The manufacturer cannot be held responsible for possible inaccuracies due to printing or transcription errors in the present booklet.

The manufacturer reserves the right to make all modifications to its products deemed necessary for manufacture or commercial reasons at any moment and without prior notice, without jeopardising the essential functional and safety characteristics of the appliances.



Cod. 1102634 - β2